

# The Globalization of Postsecondary Education: The Role of International Students in the US Higher Education System

John Bound, Breno Braga, Gaurav Khanna, and Sarah Turner

University learning has facilitated the flow of individuals and knowledge across national borders for centuries, but the recent scale of student flows and the magnitude of tuition revenues from foreign students across the globe is unprecedented. The number of students pursuing higher education degrees outside their home countries more than doubled between 2000 and 2017 to reach 5.3 million (UNESCO 2018).

For the United States, which has a large number of colleges and universities and a disproportionate share of the most highly ranked colleges and universities in the world, total enrollment of foreign students more than tripled between 1980 and 2017, from 305,000 to over one million students in 2017 (National Center for Enrollment Statistics 2018). This rising population of students from abroad has made higher education a major export sector of the US economy, generating \$44 billion in export revenue in 2019, with educational exports being about as big as the total exports of soybeans, corn, and textile supplies combined (Bureau of Economic Analysis 2020).

Traditionally, talented undergraduate and graduate students from abroad have engaged with educational opportunities that exist in the United States at a

■ *John Bound is George E. Johnson Collegiate Professor of Economics, University of Michigan, Ann Arbor, Michigan. Breno Braga is Senior Research Associate, Urban Institute, Washington, DC. Gaurav Khanna is Assistant Professor of Economics, School of Global Policy and Strategy, University of California at San Diego, La Jolla, California. Sarah Turner is University Professor of Economics and Education, Souder Family Professor, University of Virginia, Charlottesville, Virginia. Bound and Turner are also Research Associates, National Bureau of Economic Research, Cambridge, Massachusetts. Their email addresses are [jbound@umich.edu](mailto:jbound@umich.edu), [bbraga@urban.org](mailto:bbraga@urban.org), [gakhanna@ucsd.edu](mailto:gakhanna@ucsd.edu), and [set5h@virginia.edu](mailto:set5h@virginia.edu).*

For supplementary materials such as appendices, datasets, and author disclosure statements, see the article page at <https://doi.org/10.1257/jep.35.1.163>.

time when their home countries often had more limited high-quality university options. In addition, for students, especially those in fields related to science, technology, engineering, and mathematics, time spent studying in the United States has facilitated access to job opportunities, with the US visa system structured to encourage this behavior. Unlike work visas, student visas are not subject to a cap and constitute an important pathway for the foreign-born to enter the US labor market (Rosenzweig 2006; Bound et al. 2014). The participation of students from abroad in US higher education affects the global production of skills and ultimately alters the allocation of university-educated workers to labor markets in the United States and abroad. On the supply side of higher education, US colleges and universities saw the opportunity to recruit talented students and, in some cases, to generate revenue.

We begin with an overview of the basic evidence of student flows to US colleges and universities by degree level and type of institution and the visa policies which mediate these flows. We examine how factors driving the demand for higher education—reflecting socioeconomic and demographic change abroad, and supply-side factors, reflecting the behavior of US colleges and universities—impact these flows.

Finally, we explore the potential consequences of reductions in foreign student flows for talent development and labor markets in the United States and abroad. Even before the COVID-19 pandemic and accompanying recession, there was evidence that enrollment of foreign students in US higher education was slowing dramatically, driven by some combination of improved educational and employment opportunities in home countries and other non-US destinations as well as perceptions of rising US hostility to immigrants. Given the formidable levels of tuition revenue generated by foreign students, especially at the undergraduate and master's levels, any reduction in the flow of foreign students would have a direct and negative impact on university resources that would not be easily offset by other sources of support. While reductions in the flow of foreign students at the doctorate level would not lead to declines in tuition revenues—given that PhD students usually receive financial support from universities—disruptions in academic research are likely to follow, which would likely not be offset in full by growth in doctorate study among domestic students.

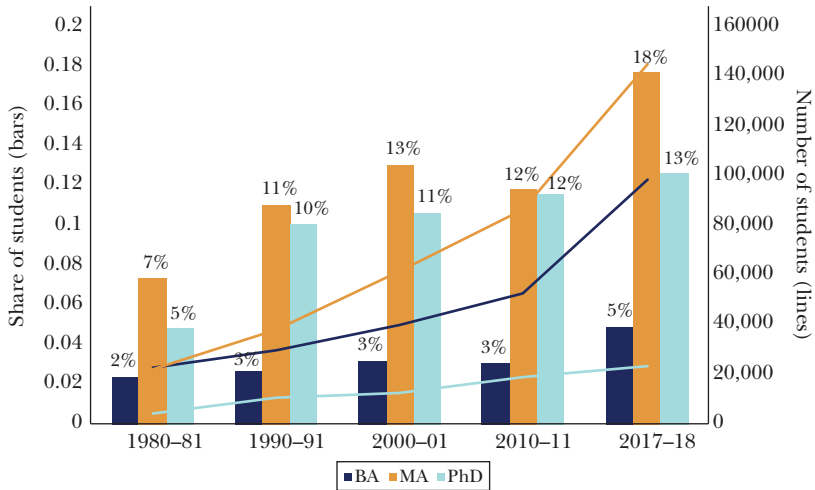
## **Trends in Higher Education Flows**

The number of foreign students enrolled in US universities at both the undergraduate and graduate levels has grown considerably over the last four decades: as noted earlier, total foreign enrollment rose from 305,000 in 1980 to over one million students in 2017 (National Center for Enrollment Statistics 2018). Foreign students as a share of total enrollment increased from 2.5 to 5.1 percent over this interval. Turning to degrees awarded by US institutions, about 5 percent of all bachelor's degrees (BAs) were awarded to international students in 2017–18, 18 percent of master's degrees (MAs), and 13 percent of doctorate degrees, as illustrated in Figure 1.

While undergraduate and graduate enrollment maintain broadly similar trajectories over the past 40 years (as indicated in Figure 1), the underlying causes of

Figure 1

**Total and Share of Non-Resident Degrees by Academic Level**



Source: IPEDS Degrees Awarded (1980–2017).

Note: BA is all undergraduate degrees, MA is all master’s degrees, and PhD is all doctoral degrees granted to non-resident students. Left axis shows the share of total (resident plus non-resident) degrees, and the right axis shows the number of degrees granted to non-residents.

enrollment growth are quite distinct, as we discuss below. In addition, over the past two decades, the rise in master’s-level enrollment has generated most of the increase in graduate enrollment. While the number of doctorate degrees awarded to international students increased by 22 percent between 2010 and 2017 (from 18,965 to 23,199), the number of master’s degrees increased by 68 percent (from 163,827 to 184,074) over the same period.

At the level of countries most likely to send students to the United States, economies in transition and those with newly opened markets often lead with growth in US enrollment at the doctorate level because these programs offer financial support in the form of fellowships, research assistantships, and teaching assistantships (Bound, Turner, and Walsh 2009). Undergraduate enrollment at US institutions then follows only after there is expansion in the pool of students able to afford the tuition of US undergraduate programs; China exemplifies this pattern with doctorate-level enrollment expanding in the 1980s and 1990s, followed by undergraduate enrollment in the 2000s. Today, China is the largest source country for enrollment at both the undergraduate and graduate levels. Other countries with substantial student flows include India, South Korea, and Saudi Arabia.<sup>1</sup>

<sup>1</sup>There was a substantial growth in the number of students in the United States from Saudi Arabia over the decade from 2003 to 2013, but this is something of a special case. Much of this growth was concentrated at the undergraduate level, increasing from 2,022 students in 2003 to 26,865 in 2013. A clear

*Table 1*  
**International Students Enrolled in Post-Secondary Institutions by Destination Country**

<i>Year</i>	<i>2000</i>	<i>2010</i>	<i>2017</i>
<i>Panel A. Students from China</i>			
Australia	5,008	87,588	128,498
Canada	4,701	26,298	66,161
United Kingdom	6,158	55,496	96,543
United States	50,281	126,498	321,625
<i>Panel B. Students from India</i>			
Australia	4,578	20,429	51,976
Canada	969	5,868	32,616
United Kingdom	3,962	38,205	16,421
United States	39,084	103,968	142,618
<i>Panel C. Students from South Korea</i>			
Australia	2,361	7,311	8,316
Canada	1,116	4,320	5,277
United Kingdom	2,165	4,347	5,157
United States	38,026	71,514	56,186

*Source:* UNESCO Institute for Statistics 2018.

*Note:* Numbers depict total number of international students enrolled across all degree statuses (undergraduate and graduate) in 2000, 2010, and 2017.

The increase in international students is not a uniquely US-centric phenomenon. Colleges and universities in Australia, Canada, and the United Kingdom also experienced a rapid increase in the enrollment of students from China and India since 2000, as shown in Table 1. Although the United States remains the largest destination country for students from these countries, the US higher education system is no longer as dominant as it was 20 years ago. As an illustration, student flows from China to the United States were more than 10 times larger than the flows to Australia and Canada in 2000; by 2017, those ratios fell to 2.5 to 1 and 3.3 to 1, respectively. Yet even as competition for international students has increased, the world market for higher education remains highly concentrated with just eight countries accounting for 58 percent of net student inflows in 2017 (UNESCO Institute for Statistics 2018)—the United States, United Kingdom, Australia, Germany, France, Russia, Canada, and Japan—and the first three of those countries accounting for 34 percent of all student imports.

---

impetus behind this increase was the introduction of the King Abdullah Scholarship Program, which stemmed from efforts to improve Saudi-US relations post-9/11, but has since grown into a substantial program aimed at boosting Saudi human capital. However, decreased budgets and new restrictions on approved universities have limited its growth since 2016. For discussion, see Saudi Arabian Cultural Bureau (2014).

### **Distribution of Students across Institutions and Fields of Study**

The enrollment of international students varies considerably across postsecondary institutions. In the 21st century, foreign enrollment of undergraduate students is largely concentrated at public research universities, including large institutions like the University of Illinois Urbana-Champaign and Purdue University, which are somewhat less selective than top private research universities. The concentration of international students at these public universities reflects their scale, but also the fact that these universities have relied on tuition revenue from foreign students to cushion the effects of falling appropriations in the last decade (Bound et al. 2020). Still, the reliance of US colleges and universities on tuition revenue from abroad is not a 21st century phenomenon. In the late 1970s, the exposure of many private colleges to risk of a foreign enrollment shock became evident when relations (and financial flows) with Iran soured, and some colleges and universities found themselves at financial risk when payments from Iran ceased (Hechinger 1979).

As shown in Table 2, foreign students studying at the undergraduate level are most numerous at research-intensive public universities (about 32 percent of all bachelor's degrees), though they also enroll in substantial numbers at non-doctorate and less selective private and public institutions. Declining state support for public colleges and universities is one factor propelling the enrollment of foreign undergraduates at public universities. Since the mid-1980s, state appropriations per student for these institutions have fallen from about \$12,000 per full-time equivalent to less than \$7,000 in 2015. For public universities, the balance between state appropriations and tuition revenues has shifted markedly over time toward greater reliance on tuition revenues, which induced publicly funded universities to seek tuition revenue from full-fee paying international undergraduates (Bound et al. 2020).

The enrollment of international master's students is more difficult to characterize. For international students, incentives for pursuing an MA degree are diverse. One is the desire to live in a major US city like New York or Los Angeles; indeed, Columbia, New York University, and the University of Southern California stand out as institutions that awarded more than 3,000 MA degrees to foreign students in 2016. For some international master's students, these programs provide skills and credentials to strengthen applications to US doctorate programs, while for others, MA-level study yields direct access to employment options in the United States, particularly in areas where information technology-related industries are expanding.<sup>2</sup> In particular, the enrollment of students from India is typically concentrated in master's programs, with more than 90,000 Indian students enrolled in master's programs in 2015. It is also noticeable that some less selective public universities, such as the

<sup>2</sup>Focusing on MA degrees in computer science and information technology-related fields, Bound et al. (2014) note that there is substantial heterogeneity in the programs awarding degrees to temporary residents. Institutions awarding large numbers of master's degrees in computer science to temporary residents in 2013 include Carnegie Mellon University (464), Illinois Institute of Technology (397), University of Southern California (377), Columbia University in the City of New York (292), and University of Texas at Dallas (214). Ghose and Turner (2020) demonstrate the sensitivity of MA enrollment from foreign students to labor demand variation, with much of the MA enrollment changes concentrated among less-selective and for-profit institutions.

Table 2

**Distribution of Foreign Students at Public and Non-Profit Universities and Tuition Status, 2015**

<i>Degree type</i>	<i>Institution type</i>	<i>Number of degrees</i>	<i>Tuition and fee</i>	<i>Expected student payment</i>	<i>Fully funded</i>
<i>Panel A. Private, non-profit universities</i>					
BA	Non-Doctorate	16,518	\$31,138	\$20,355	13%
BA	Other Doctorate	5,930	\$37,526	\$30,486	5%
BA	Very High Research Doctorate	7,332	\$45,266	\$38,466	11%
MA	Non-Doctorate	20,452	\$20,358	\$17,748	3%
MA	Other Doctorate	14,102	\$26,564	\$24,313	3%
MA	Very High Research Doctorate	30,096	\$45,512	\$39,858	5%
PhD	Non-Doctorate	348	\$27,353	\$20,589	20%
PhD	Other Doctorate	908	\$25,667	\$10,645	51%
PhD	Very High Research Doctorate	4,116	\$38,451	\$4,394	87%
<i>Panel B. Public universities</i>					
BA	Non-Doctorate	15,435	\$15,324	\$13,099	6%
BA	Other Doctorate	10,549	\$20,313	\$18,321	6%
BA	Very High Research Doctorate	26,187	\$29,245	\$28,249	2%
MA	Non-Doctorate	15,128	\$13,899	\$12,918	5%
MA	Other Doctorate	21,649	\$18,020	\$15,517	10%
MA	Very High Research Doctorate	32,423	\$27,410	\$23,709	11%
PhD	Non-Doctorate	414	\$14,613	\$4,857	73%
PhD	Other Doctorate	2,936	\$16,217	\$4,498	72%
PhD	Very High Research Doctorate	9,771	\$22,238	\$4,504	79%

*Source:* IPEDS Degrees for the number of degrees and F-1 visa administrative data, from United States Citizenship and Immigration Services (USCIS) for the other statistics.

*Note:* “Very High Research Doctorate” are universities classified as having very high research activity by the Carnegie 2010 classifications. “Other Doctorate” are universities classified as having high research activity by the Carnegie 2010 classifications and other Doctoral-awarding universities. “Non-Doctorate” are all other post-secondary institutions. “Tuition & Fees” are the average tuition and fee charged to the foreign student. “Expected Student Payment” is the average tuition and fee not funded by the post-secondary institution. “Fully funded” is the share of students who are fully funded by the post-secondary institution.

University of Central Missouri and the University of Texas at Dallas, have a high number of foreign master’s-level students. While lower prices than more highly ranked institutions may be part of the attraction of these institutions for foreign students (Redden 2017), it is also the case that many of these colleges actively pay foreign recruiters; for example, Chen and Korn (2015) report that Wichita State pays foreign agents between \$1,000 and \$1,600 per student for recruiting.

Naturally, doctorate-level students are concentrated at research universities (Table 2), with public research universities having a somewhat higher level of foreign PhD degrees. Public research universities provide both greater scale and large programs in engineering, science, and technology fields, which tend to attract foreign students.

International students represent a higher share of students in science, technology, engineering, and mathematics programs than in any other fields at the bachelor’s,

master's, and PhD levels (Figure A1 in the online Appendix available with this article at the *JEP* website). In fact, about 17 percent of all BA degrees in mathematics were awarded to temporary residents in 2017. The concentration of international students in master's programs in the fields of science, technology, engineering, and mathematics is even more remarkable: for example, in 2017 foreign students received about 62 percent of all master's degrees in computer science and 55 percent in engineering. Nonetheless, the representation of foreign students was higher in 2017 than 2002 in virtually all fields in both bachelor's and master's programs.

## **Visa Policy for Foreign Study in the United States**

International students enter the United States on F, J, or M student non-immigrant visas: the F-1 student visa is the primary mode for full-time foreign students, J-1 visas are for exchange students and researchers, and the less frequently used M-1 visa is for those attending vocational or technical education. F-1 students must first be accepted by a US higher education institution certified by the Student and Exchange Visitor Program (SEVP), which provides the student with a certificate of eligibility for non-immigrant student status (the I-20 form). The student pays a SEVIS (Student and Exchange Visitor Information System) fee to the US Citizenship and Immigration Services (\$200 in 2020) and applies for a visa at a US Embassy before entering the United States. To remain in legal status, the student must maintain a full course load but can engage in part-time work at the college or university.

The term of an F visa can be extended beyond formal academic enrollment through participation in Optional Practical Training (OPT), which allows for temporary employment related to a student's major area of study. This option provides an extended period in the United States for a foreign student to search for employment outside the constraints of a numerical visa quota. In 2008, the duration of the OPT was extended from 12 to 29 months for those in science, technology, engineering, or mathematics fields. An administrative change extended the number of designated programs from about 90 to nearly 400 in June 2012, and another change extended the term to 36 months in 2016.

Student visas differ from work visas in that they are largely unconstrained in quantity. The primary work visa for those with a college degree is the H-1B, which requires that the employee be in a specialty occupation, defined as one that requires "theoretical and practical application of a body of highly specialized knowledge and attainment of a Bachelor's or higher, or its equivalent." H-1B visas require an employer application and sponsorship, and their use in the private sector is subject to a cap (currently binding at 65,000 per year with some additional allowances) for all foreign workers except those from five exempt countries (Canada, Mexico, Chile, Singapore, and Australia).<sup>3</sup> While binding in the private sector, higher education institutions,

<sup>3</sup>Although the original H-1 visa did not have a numerical cap, the Immigration Act of 1990 imposed an annual cap of 65,000 visas. This total was not reached during the early 1990s, but the cap became binding in the mid-1990s. In 1999 and 2000, the cap was raised to 115,000, and then to 195,000 in 2001. This limit held until 2004, when the H-1B cap reverted to 65,000 once again. In 2004, Congress authorized,

nonprofit research organizations, and government agencies are exempt from the H-1B visa cap, providing an additional pathway to the labor market for individuals studying in the United States on F visas. As a result, students from H-1B-dependent countries became more likely to work in academic institutions when the H-1B cap became binding in 2004 (Amuedo-Dorantes and Furtado 2019).

In Figure 2, panel A presents the different types of high-skill visas and the transitions between them. Panel B shows the number of visas for each category issued between 1997 and 2018. It demonstrates the lack of numerical constraints on student visas—since the mid-2000s, student visas have increased sharply, even as the numbers dwarf the frequently debated H-1B visa program. Student visas are an important pathway into the US labor market. Yet, as the figure shows, the transition rates from student visas to work visas have steadily declined over time because even as student visas have increased, the number of new H-1B visas has stayed roughly constant.<sup>4</sup>

After graduating from US higher education institutions, foreign students have three primary options. First, they may enroll in a different degree program with a new F-visa, such as when continuing from a bachelor's to a master's program or from a master's to a PhD program. Second, they may start working for a US employer either through an OPT extension on the same F-visa or through a work visa, such as an H-1B. Their third option is to leave the country. Alternative options include a direct path to permanent residency as a spouse/relation of a US citizen.

Because student visas are an important stepping-stone for participating in the US labor market, changes to visa policy and the availability of H-1B opportunities will affect decisions to study in the United States (Kato and Sparber 2013). Indeed, policy adjustments such as the extension of the OPT period for F-1 degree recipients in science, technology, engineering, and mathematics fields and a rule-making change favoring US advanced degree recipients in the allocation of H-1B visas potentially affect both foreign educational investments and persistence in the US labor market (Radnofsky 2019; Amuedo-Dorantes, Furtado, and Xu 2019). In effect, growth in the student visa reservoir and the pool of students persisting with OPTs increases the supply of foreign-born college-educated workers in the United States and effectively lengthens the queue for employment visas such as the H-1B and employment-based permanent residency.

In recent years, other countries have begun competing with the United States for high-skilled immigrants by offering policies that provide somewhat flexible options for transitions to employment. Both Canada and Australia have programs which allow foreign-born graduates to stay in the country after they finish their studies. They also use these programs to feed their permanent residency point-based selection program (Moltaji 2017; Crown, Faggian, and Corcoran 2020). For example, obtaining a Canadian post-secondary educational credential generates extra points in the Express Entry

---

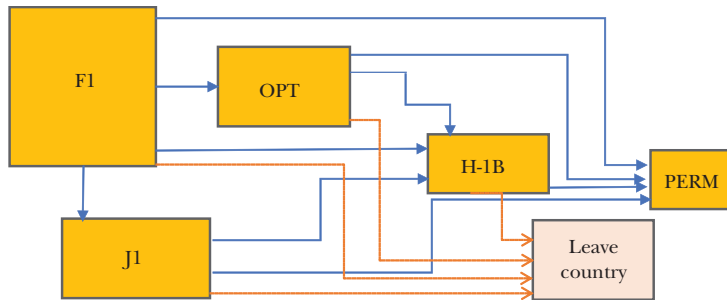
through the Visa Reform Act, that an extra 20,000 H-1B visas could be issued to foreign workers holding advanced degrees from US universities.

<sup>4</sup>Since 2016, there has been a drop in new student visas, perhaps reflecting a change in the visa renewal requirements of Chinese students as well as other global trends in the demand for higher education from abroad. In 2014, Chinese students were given an extension for their F-1 student visas, making them valid for five years instead of one.

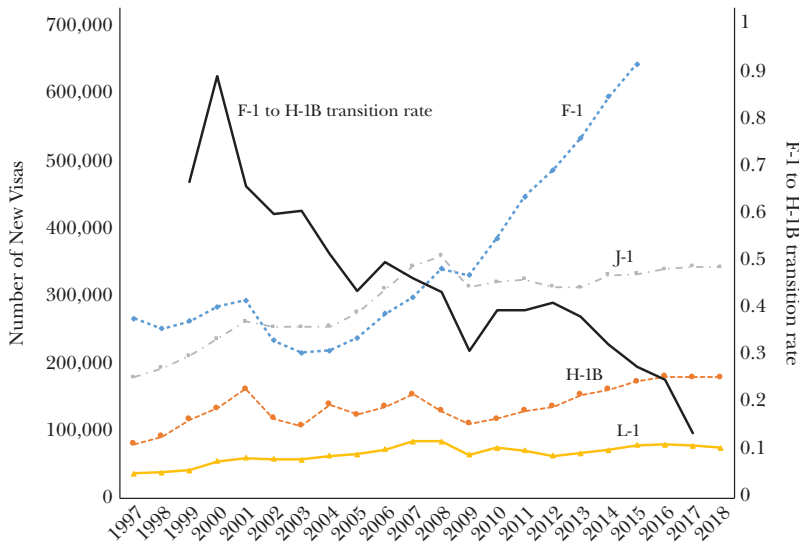


Figure 2  
**Transitions from Student to Work Visas**

A: Description of transition paths out of the Student Visa



B: New Visas awarded and transition rates, 1997–2018



Source: United States Department of State (1997–2015)

Note: Panel A shows the transition paths for F-1 visa recipients. Panel B shows the trends over time in visas granted and transition rates from F-1 to H-1B visas. The F-1 visa is the student visa applicable to most students at certified US universities. OPT is Optional Practical Training which allows those on an F-1 visa to work for a US-based employer post graduation. The J-1 visa is for exchange students, researchers, and physicians undergoing training (including international medical graduates for medical residencies). The L-1 visa is for intra-company transfers of executives and managers. The H-1B visa is for high-skill workers in specialty occupations. PERM is applications for immigration status (green cards). The sizes of the boxes in Panel A crudely, but not accurately, depict the number of visas granted. In Panel B, the right-axis uses USCIS data to estimate the fraction of F-1 visas that converted to an (new, initial employment) H-1B visa each year. For the transition rates we use the 2000–2018 Characteristics of H-1B Specialty Workers Reports of the USCIS, and the 1999–2018 Completion Surveys by Race from the Integrated Post-Secondary Data System. The ratio of initial H-1B petitions processed to aliens in the United States to the number of foreign graduates of US universities in that class of graduation is an approximation of the transition rate from F-1 visas to H-1B for each year of graduation. We omit the F-1 visa data after 2015 because of the change of visa regime in visa renewals for Chinese students.

system used by Canada to select economic migrants (Canada Express Entry 2020). Applicants are also awarded extra points in the Australian Skilled Immigration Points Requirements if they completed their education from an Australian educational institution (Australian Department of Home Affairs 2020). Such competing immigration policies may, in turn, diminish the US advantage in attracting global talent.

## **The Demand for US Higher Education from Abroad**

Demand for admission to US degree programs—like programs in other foreign countries—depends on the number of individuals academically prepared for post-secondary study, the availability of home country university options, individuals' capacity to pay for education abroad, and the extent to which enrollment provides a pathway to the US labor market. Because the home country supply of university opportunities tends to be fairly inelastic in the short term (particularly in the research-intensive sectors), enrollment in US degree programs is one way to satisfy demand for university education that cannot be immediately accommodated by expansion in home countries. These forces generate predictable patterns in which economic growth in a developing country fuels increases in US enrollment, with doctorate enrollment often leading undergraduate enrollment. Eventually, the country's enrollment flow to the United States (or other countries) will stabilize or decline as home-country capacity increases.

For many developing countries, the opening of education markets to the United States is a first step in a transition that includes improved diplomatic relations and the broader opening of markets to international trade. For instance, the establishment of diplomatic relations between China and the United States in 1979 dramatically increased the level of educational exchange between these two countries, particularly at the doctorate level, with similar patterns evident in the post-Cold War era for students from Eastern Europe and the former Soviet Union in the late 1980s and early 1990s tied to political changes in those countries (Blanchard, Bound, and Turner 2009). Conversely, political developments have also sometimes worked to close down foreign student enrollment (and trade more generally), as happened for students from China in the early 1950s, Hungary in the mid-1950s, and Iran after the 1979 Iranian Revolution.

Changes in educational attainment and personal incomes in developing countries have been a major driver in the overall growth in demand from abroad for US post-secondary education. For countries like South Korea, Singapore, Taiwan, China and India, the upward trend in secondary and post-secondary attainment in recent decades has been remarkable. China experienced an increase of 15 million in the number of students enrolled in secondary education between 1997 and 2017 (from about 68 million students) and an increase of 38 million in students enrolled in post-secondary education (from about 6 million) during the same period (UNESCO Institute for Statistics 2018). In 2017, India had 61 million more students enrolled in secondary education and 27 million more students enrolled in a post-secondary education than in 1997.

These dramatic growth trajectories were not matched by immediate expansion in home country university capacity, at a time in the 1980s and 1990s when opportunities for study at home country research universities comparable to highly ranked North American or European research universities were very limited. In 2003, no universities from China were among the 50 most highly ranked universities in the world, while universities from the United States occupied 39 of the top 50 spots. Today, two universities from China have entered this elite group, while US universities represent 31 of the 50 most highly ranked universities in the world (Shanghai Ranking 2020). Massive Chinese government investments in research and university education in the last two decades have produced expansion of home-country capacity for both undergraduate and graduate education: specifically, Project 985 promotes the 39 top universities in China, while Project 211 targets the top 112 universities.

At the undergraduate level, enrollment demand for US institutions from foreign students reflects the presence of types of programs rarely available in other countries, including liberal arts colleges and other broad-based programs of study, along with a greater supply of selective and resource-intensive options. Even as China and India have developed highly competitive elite universities, and their capacity has grown in the last two decades, seats are so scarce at these institutions that admission to top-ranked US colleges may be no more difficult; indeed, Najjar (2011) provides evidence that some of the most qualified students in India are being crowded out of top Indian colleges.

For countries like China, enrollment in US and other foreign doctorate programs increased before the growth in enrollment in undergraduate and master's-level programs charging tuition. The upward trajectory in doctorate enrollment started in the 1980s even as the growth in undergraduate enrollment did not escalate until the 21st century (Bound, Turner, and Walsh 2009). In the 1980s and 1990s, US universities awarded more PhDs to students from China than did Chinese universities. Because foreign doctoral students commonly receive full support in the form of fellowships and teaching assistantships, their enrollment is often less sensitive to home country income.

Over the past 20 years, a substantial number of households in developing countries have experienced increasing income levels, which provide them with the capacity to pay for US higher education (Bird and Turner 2014). For instance, Bound et al. (2020) estimate that the fraction of Chinese families with incomes greater than the average amount charged by US public universities for out-of-state tuition and room and board grew from 0.005 percent in the year 2000 to more than 2 percent by 2013. This growth in the ability of Chinese families to pay for a US education in the first part of the 21st century allowed US universities to enroll increasing numbers of qualified full-fare paying students from abroad, particularly at the undergraduate and master's levels.

Chinese cities experiencing the largest income growth induced by increased goods exports were among those with the greatest outflow of international students to US universities (Khanna et al. 2020). In effect, Chinese families in locally booming economies used some of their new trade-liberalization driven wealth to send students abroad. This response of flows to income growth was strong for students

at the undergraduate and master's level and not detectable at the doctorate level. Accordingly, the response was also strongest among self-funded students. This is not only a demonstration of the effects of income growth on US enrollment but also demonstrates how the US trade deficit in goods with China partially cycled back as an export surplus in higher education services.

Beyond (potential) access to post-secondary options unavailable in their home countries, obtaining a US degree provides the advantage of potentially easier access to US employment options (Rosenzweig 2006; Bound et al. 2014).<sup>5</sup> Because most students graduating from a US university are eligible for an extension of their visas with the pursuit of Optional Practical Training, they are able to gain employment in the US labor market without needing an H-1B visa in the supply-constrained lottery. In addition, obtaining a degree from a US college or university may provide advantages for foreign students searching for jobs over those educated abroad, to the extent that US employers have more information on skills acquired at familiar educational institutions, and employers might find it more straightforward to interview candidates on-site. Moreover, the likelihood that foreign students stay in the United States after finishing their studies is also a function of economic conditions in their home countries. Generally, students from higher-income nations are less likely to convert their student status to OPT than students from lower-income countries, as shown in Figure 3. For example, about 65 percent of all US bachelor's graduates from India switched to OPT in 2015, while only 28 percent of Canadian graduates switched to OPT over the same period.

In turn, as the option value of pursuing employment in the US changes, we would expect enrollment demand from abroad to adjust. Using the number of takers of the Graduate Record Examination (GRE) as a measure of students' willingness to come to the United States for graduate education, for most of the past two decades, the demand from Indian students for a US education has been higher when US unemployment rates are low. Nonetheless, there has been a significant drop in the number of Indians taking the GRE since 2016, a period with several years of low unemployment rates. One potential explanation for this is a perception of less willingness of the United States to welcome immigrants after the 2016 election, which makes the United States less attractive to international students (Anderson and Svrluga 2018).

## **The Supply Side: How US Colleges and Universities Benefit from Foreign Students**

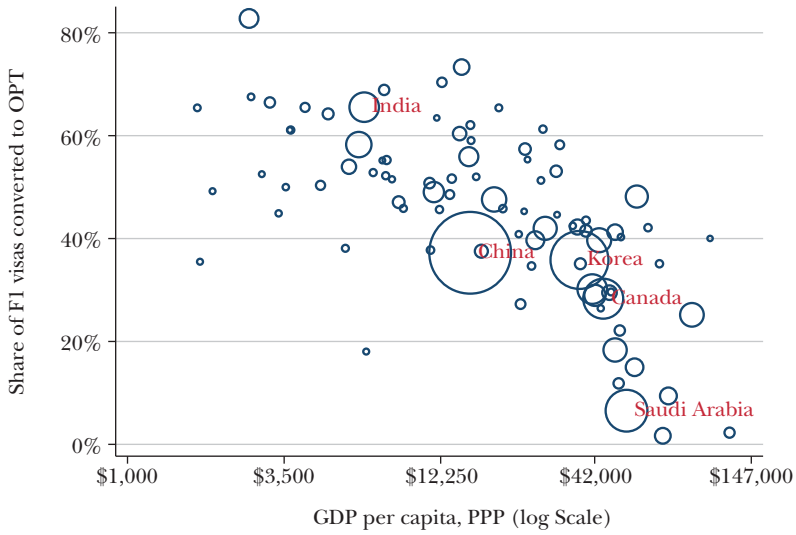
US colleges and universities seek talent and resources from international students. The relative importance of academic skills and capacity to pay varies markedly by degree level and type of university.

<sup>5</sup>Amuedo-Dorantes, Furtado, and Xu (2019) find evidence that when the OPT policy was changed in 2008 to extend the time for science, technology, engineering, and mathematics graduates to stay in the United States after graduation, it induced an increasing number of foreign students to major in these fields.

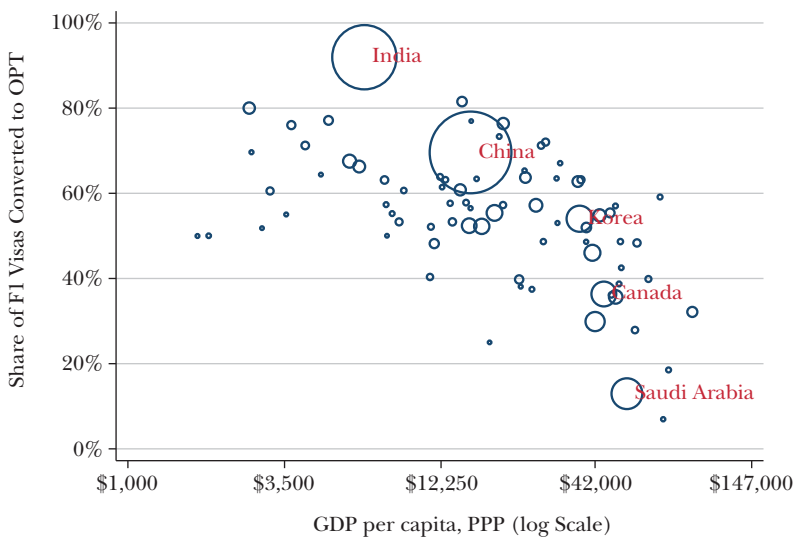
Figure 3

Share of F1 Visas Converted to Optional Practical Training by Country's Per Capita GDP

A: Bachelor's Degree



B: Master's Degree



Source: 2015 F-1 visa administrative data from United States Citizenship and Immigration Services (2015) and World Development Indicators database, World Bank (2020).

Note: Size of each bubble is proportional to the number of foreign graduates in 2015. Sample is restricted to countries with more than 50 graduates in 2015.

For most doctoral students, capacity to pay is secondary (and often irrelevant), as admission to many PhD programs is accompanied by full tuition waivers and guaranteed living expenses for multiple years. At the other extreme, many master's degree and undergraduate programs have quite modest academic requirements and can attract foreign students who are able to pay tuition levels that relatively few US students are willing to pay in full. Occupying a middle ground are selective colleges and universities that face excess demand for undergraduate programs along with professional programs like the MBA. These institutions, often competing on quality, see both academic talent and capacity to pay undiscounted or out-of-state prices among foreign students as inputs in their objective functions.

University admission offices typically employ a variety of recruitment strategies to attract international students, ranging from utilizing social media to traveling abroad to meet with students, parents, counselors, and alumni at schools and education fairs. In addition, several institutions started experimenting with commission-based recruitment agents in the past years. If contracted by colleges, these commissioned agents are paid on a per capita basis. As of 2017, 38.5 percent of US colleges and universities reported using commission-based recruitment agents—up from 30 percent in 2010 (National Association for College Admission Counseling 2018).

### **Revenue Implications**

It would be naïve to understate the revenue implications of foreign students for US colleges and universities. In 2019, foreign students poured nearly \$44 billion into the US education system (Bureau of Economic Analysis 2020). The revenue implications from tuition differ markedly by degree level, as shown in Table 2. BA and MA students rarely have a “free ride,” while it is quite common for doctorate-level students to have university resources cover tuition and fees. International undergraduate students pay nearly 96 percent of tuition costs from personal or home country sources at public research universities.

Among undergraduate students at private universities, the share of tuition paid by individuals is somewhat smaller but the levels are higher, reflecting the higher tuition prices at private institutions. Two different factors yield a modest wedge between the sticker price and what students pay for foreign students at the undergraduate level: first, a modest number of very wealthy private institutions like Princeton University provide some financial aid for foreign undergraduates, and second, somewhat less selective private universities regularly engage in “discounting,” which refers to offering need-based financial aid to increase enrollment (Bowen and Breneman 1993).

Foreign students studying at the MA level represent a significant source of revenue in both the public and private sectors of higher education, representing \$3 billion and \$4.3 billion in revenues respectively. Although top research universities have the largest numbers of master's students and are able to extract the highest prices (net tuition revenue of \$39,858 on a posted tuition and fee level averaging \$45,512), there are also many full-pay foreign students outside this tier in the public and private sectors..

The importance of MA-level training for foreign students as a revenue source for universities has increased markedly in recent years, with a number of universities

adding revenue-generating programs precisely to cater to foreign students. For example, the number of master's programs in the United States where 80 percent or more of the graduates were foreign rose slowly, from 354 in 2000 to 512 by 2012.<sup>6</sup> But with declining state appropriations and stagnant federal funding for science over the last decade (National Science Board 2020, Figure 5B-4), the number of such programs leaped, reaching nearly 1,000 by 2016 (Education Data Portal 2020). The growth has primarily been in science, technology, engineering, and mathematics programs, where demand from full-pay students from abroad may cross-subsidize doctorate programs.

In an accounting sense, doctoral programs are cost drivers, not sources of revenue generation, and this pattern evidently holds true for foreign students as well as domestic students. Using data on total cost of attendance (which includes living expenses), universities in the private and public sectors make a substantial investment in foreign doctoral students. For 2015, average total expenses (tuition and living expenses) for doctorate students at top private research universities were nearly \$62,000, with funds from universities averaging \$55,572 (about 90 percent of the total); at public research universities, the comparable numbers are \$39,803 in total expenses, with \$34,396 funded from universities (although some of what appears as university funding may reflect grant funding from federal or private sources allocated at the university level). Foreign doctorate students contribute not just to the research and teaching enterprise but also to university prestige, particularly at universities looking to establish their competitive research credentials. Moreover, the presence of doctorate programs may help recruit and retain research-active faculty who are likely to gain from the capacity to teach small courses tied to research specialties (Courant and Turner 2019).

## **Consequences of International Student Flows**

Dramatic increases (or decreases) in foreign student flows may have implications not only for the university sector, but also for labor markets and the broader economy in both the sending and receiving countries. A body of work examines such consequences, most notably focused on the consequences on the native-born, innovation, and higher-education institutions in the United States.

One obvious question is whether the spillovers of international flows of students on native students is beneficial. On the negative side, there is some indication that foreign PhD students “crowd out” domestic students (Borjas 2007), presumably in contexts where there are capacity constraints on enrollment along with an excess demand for slots among domestic students. In addition, there is some indication that at the undergraduate level, the concentration of international students in certain majors like business, economics, or science and engineering may dilute per-student resources or lead local students to concentrate in other fields (Anelli, Shih, and Williams 2017). Some suggest that growth in foreign students may have

<sup>6</sup>These calculations are restricted to programs with at least five students.

generated institution-level administrative challenges, while others have questioned how well foreign students are integrated at US universities (Jordan 2015; Redden 2014; Gareis 2012).

Yet much evidence also points to the potential cross-subsidization of native students. International students are an important source of revenue for public research universities facing declining state appropriations (Bound et al. 2020). Without a ready supply of foreign students, such universities would have had to navigate reductions in instructional resources per student or substantially raise in-state tuition. Such cross-subsidization may also be present in graduate programs, specifically in terms of revenue from master's programs (Shih 2017). Revenue-generating master's programs are not only more likely to charge full sticker price than subsidized PhDs, but they are also relatively more elastic in their supply. Many large research institutions now draw as much as 20 percent of their tuition revenue from foreign students (Larmer 2019). Universities may invest in programs and centers better aligned with the demands of foreign, rather than local, students. Yet, the revenue from international students may also help institutions better cater to the preferences of local students. Of course, this pattern also makes these institutions more dependent on foreign flows, which will fluctuate in response to global political crises, home-country economies, growth in home-country institutional quality, and competition from other developed economies like Canada, the United Kingdom, and Australia.

International student flows also help generate a ready supply of high-skill foreign workers for the US labor market. The OPT program mentioned earlier allows students between one and two years of additional labor market experience in the United States post-graduation, and the stringently capped high-skill H-1B program has a separate category of 20,000 visas that makes it easier for foreign citizens who have a graduate degree from US universities. Such features help facilitate the transition to the US workforce. In turn, the pool of foreign students considering US employment facilitates matches and reduces the monopsony power employers have over their foreign workers.<sup>7</sup>

Foreign students looking for work in the United States are likely to have spill-over effects on US students for a combination of reasons. For example, the presence of foreign students who may be willing to accept a lower wage may disadvantage US-born students. There is reason to believe that had firms not been able to hire H-1B workers, the wages of US computer scientists would be even higher than they are (Bound et al. 2015; Bound et al. 2013). As a result of constrained wages, fewer Americans may decide to pursue fields likely dominated by foreign graduates.

Additionally, some limited and anecdotal evidence exists that the expansion of Optional Practical Training combined with the potential for limited employment while enrolled has contributed to the rise of fraudulent post-secondary institutions. One such example is the case of Tri-Valley University in California, which appeared

<sup>7</sup>Much of the criticism leveled at the H-1B program involves the limited mobility H-1B workers have. Similarly, to be eligible for the OPT extensions, foreign students need to find jobs within two months of finishing their degree.



to have nearly 1,000 students enrolled on F-1 visas in May 2010, with 185 listed as pursuing a doctorate degree in Computer Science. The institution was shut down in 2011 by Immigration and Customs Enforcement with the founder charged with fraud and money laundering.<sup>8</sup> While cases of outright fraud are likely to represent a very small share of the utilization of OPT and the extended provisions associated with degrees in science, technology, engineering, and mathematics, there is a legitimate question of how the extension of the OPT from 12 to 29 months in 2008 for recipients in these fields affected outcomes in the United States. Demirci (2015) finds increases in the incidence and duration of persistence in the United States for F-1 visa recipients at least in the immediate period after degree completion, with these effects particularly marked for master's degree recipients.

While the rates at which foreign students stay in the United States after receiving their degrees are difficult to measure at the undergraduate and master's level, the five-year stay rate for doctorate recipients exceeds 70 percent and is higher for those from China (84 percent) and India (86 percent) than from other countries (authors' calculations using the Survey of Earned Doctorates). Similarly, at the PhD level, Finn and Pennington (2018) find that 10-year stay rates (2002–03 to 2013) were highest among students from China and India (85 percent), with students from South Korea, Europe, and the Americas less likely to stay. Yet stay-rates for doctoral students are unlikely to translate to other levels of degree receipt; as Figure 2 showed earlier, given the capped nature of work visas and the rising number of international students, the transition rates from F-1 student to H-1B work visas have been steadily declining.

Transitions to the US workforce are often concentrated in high-skill sectors, such as information technology and health care (Bound et al. 2014). Foreign workers may help facilitate innovation and production by allowing firms to draw from a large pool of global talent abroad (Kerr 2018). Indeed, a number of studies have identified the outsized role played by immigrants in science and engineering innovation, including elite settings like membership in the National Academy of Sciences, Nobel prize receipt, and authorship of very highly cited papers (for example, Chellaraj, Maskus, and Mattoo 2008; Black and Stephan 2010; Stuenkel, Mobarak, and Maskus 2012; Gaulé and Piacentini 2013). Immigrants have also played prominent roles in tech entrepreneurship (Anderson and Platzer 2006; Saxenian 2000; Wadhwa et al. 2007). But not all immigration in the tech field is concentrated in the tail end of the distribution of innovation and productivity; for example, using patent data, Hunt and Gauthier-Loiselle (2010) find that, conditional on occupation, immigrants are equally likely to innovate as US-born workers.

<sup>8</sup>A report in the *Chronicle of Higher Education* suggests, “Tri-Valley is only the beginning. Other colleges—most of them unaccredited—exploit byzantine federal regulations, enrolling almost exclusively foreign students and charging them upward of \$3,000 for a chance to work legally in the United States. They flourish in California and Virginia, where regulations are lax, and many of their practices—for instance, holding some classes on only three weekends per semester—are unconventional, to say the least. These colleges usher in thousands of foreign students and generate millions of dollars in profits because they have the power, bestowed by the US government, to help students get visas” (Bartlett, Fischer, and Keller 2011).

Although it is relatively straightforward to enumerate the contributions of skilled immigrants educated in the United States, assessing their overall effects on the US economy involves evaluating counterfactuals. If there is some crowd-out of US-born workers, then enumerating the contributions of skilled immigrants will exaggerate their net contributions. On the other hand, if the crowd out is less than total, as would seem likely in most cases, then the net contribution will be positive. Outside specific contexts, accurately gauging magnitudes is probably not possible.

Labor market opportunities may also have substantial impacts on home economies. Sending countries may experience “brain drain” as bright minds move abroad. On the other hand, the potential to migrate abroad may encourage the foreign-born to acquire skills (such as undergraduate engineering degrees) that are valued abroad. Such a “brain gain,” combined with return migration at a later time, may facilitate the shifting of knowledge and production to home countries (Khanna and Morales 2019). Indeed, PhDs trained in the United States and other western countries may have fostered the growth of tertiary education and scientific research in a range of counties (Kahn and MacGarvie 2016).

Evaluating the effect that the availability of foreign students interested in and capable of attending US universities has on these institutions and the US economy more generally will often involve important feedback effects between the educational sector and the rest of the economy, as we have emphasized. For instance, changes in the US H-1B program are likely to have significant effects on the demand for education by both foreign and domestic students. Further, US immigration policy interacts with other features of the US economy including, for example, state higher education funding decisions. Evaluating the relevant counterfactuals essentially involves working implicitly or explicitly with general equilibrium models.

## **Moving Forward: The Future of the Higher Education Sector**

The flow of foreign student revenues and talent from abroad has had a substantial impact on US higher education in recent decades. As such, market forces, political crises and the COVID-19 pandemic that can destabilize these flows are likely to result in reduced resources for US higher education institutions, with such shocks reverberating to the economy more broadly. To that end, universities have started taking precautionary measures like consciously diversifying their portfolio of origin countries, and even taking out insurance policies to cover themselves against losses to foreign-student revenue (Bothwell 2018).

Political concerns following the escalation of US-China trade relations in 2018, along with the handling of the pandemic that erupted in 2020, may curb the flow of foreign students from abroad. Khanna et al. (2020) estimate that if the US-China trade war continues, it could cost US universities about 30,000 Chinese students or \$1.15 billion in revenue over the next 10 years. This loss, which would be about 8 percent of educational service exports to China, is likely an underestimate of overall economic losses for the US economy as it does not account for broader effects on local economies surrounding universities. More generally, changes to the

likelihood of obtaining a US work visa may discourage many students who were looking at US education as a stepping-stone to the labor market. For the first time in many decades, new foreign undergraduate enrollment has declined.

At the same time, universities in other parts of the world have become global players in this market and threaten the dominance of the US position in attracting foreign students. In particular, the expansion of home-country higher education capacity may keep students back in China or India. In India, the expansion of numerous Institutes of National Importance may stem the outflow of bachelor's students. These Institutes are primarily teaching-based, but do produce a stream of high-quality students ready for graduate programs.<sup>9</sup>

China has recently increased investments in both the instructional and research capacity of their higher education institutions. One of the most prominent global rankings for universities is the Academic Ranking of World Universities originated by China's Shanghai Jiao Tong University and thus commonly known as the Shanghai rankings. According to these rankings, the US share of the world's top 500 research universities fell about 7 percentage points from 2004 to 2018, from 35 to 28 percent, while the share of Chinese research universities in the top 500 accounted for most of this change by rising 8 percentage points from 2 to 10 percent (Appendix Figure A2). On the margin of the top 500, Chinese universities are "overtaking" some lower mid-tier US institutions. Such changes may affect the future flow of students from abroad. This, in turn, would affect the size of the science and technology workforce produced by and working in the United States, and the corresponding location of innovation and economic activity.

US universities are experiencing drastic revenue shortfalls in the second half of 2020 and beyond as a result of the COVID-19 crisis. For instance, these near-term losses are projected to be \$250 million at the University of Delaware (as reported in Flaherty 2020), \$300 million at the University of North Carolina Chapel Hill (Murphy 2020), and \$500 million for university system in Maryland (Condon 2020). Possible in-person enrollment reductions in the summer and fall, and tightening visa and mobility restrictions, tend to exacerbate these shortfalls. As such, universities most reliant on foreign enrollment may be most adversely affected. These include schools in the University of California system, and large Midwestern universities, such as Purdue, University of Illinois at Urbana-Champaign, and Michigan State, all of which enroll a relatively large number of their incoming first-year undergraduates from China (Bound et al. 2020).

Visas for the academic year are usually granted between March (when admissions decisions are made) and September (when semesters begin). Between 2017 and 2019, about 290,000 visas were granted each year over these seven months (United States Department of State 2020). Between March and September 2020, only 37,680 visas were granted—an extraordinary drop of 87 percent. Visas for students from China dropped from about 90,000 down to only 943 visas between March and September 2020. A fall 2020 survey of 700 higher education institutions found that

<sup>9</sup>Institutes of National Importance specialize in both undergraduate and post-graduate education in technical fields like medicine, information technology, sciences, engineering, architecture or business.

one in five international students were studying online from abroad in response to the COVID-19 pandemic. Overall, new international enrollment (including those online) decreased by 43 percent, with at least 40,000 students deferring enrollment (Baer and Martel 2020). Not only does the absence of international students from campuses in the 2020–21 academic year impact college-town economies and university dorm revenues, but the disruption in the flow of new international enrollment may have lasting impacts on university finances and academic outcomes.

■ *We thank the National Science Foundation for generous research support. We are grateful to Nathaniel Ruby for superb research assistance.*

## References

- Amuedo-Dorantes, Catalina, and Delia Furtado.** 2019. "Settling for Academia? H-1B Visas and the Career Choices of International Students in the United States." *Journal of Human Resources* 54 (2): 401–29.
- Amuedo-Dorantes, Catalina, Delia Furtado, and Huanan Xu.** 2019. "OPT Policy Changes and Foreign Born STEM Talent in the US." *Labour Economics* 61.
- Anderson, Nick, and Susan Svrluga.** 2018. "What's the Trump Effect on International Enrollment? Report Finds New Foreign Students Are Dwindling." *The Washington Post*, November 13.
- Anderson, Stuart, and Michaela Platzer.** 2006. "American Made: The Impact of Immigrant Entrepreneurs and Professionals on US Competitiveness." Washington, DC: National Venture Capital Association.
- Anelli, Massimo, Kevin Shih, and Kevin Williams.** 2017. "Foreign Peer Effects and STEM Major Choice." IZA Discussion Paper 10743.
- Australian Department of Home Affairs.** 2020. *Points Table for Skilled Independent Visa (Subclass 189)*. Canberra: Government of Australia.
- Baer, Julie, and Mirka Martel.** 2020. *Fall 2020 International Student Enrollment Snapshot*. New York: Institute of International Education.
- Bartlett, Tom, Karin Fischer, and Josh Keller.** 2011. "Little-Known Colleges Exploit Visa Loopholes to Make Millions Off Foreign Students." *The Chronicle of Higher Education*, March 20. <https://www.chronicle.com/article/Little-Known-Colleges-Make/126822>.
- Bird, Kelli, and Sarah Turner.** 2014. "College in the States: Foreign Student Demand and Higher Education Supply in the U.S." [https://curry.virginia.edu/sites/default/files/uploads/resourceLibrary/23\\_Bird\\_Foreign\\_Student\\_Demand.pdf](https://curry.virginia.edu/sites/default/files/uploads/resourceLibrary/23_Bird_Foreign_Student_Demand.pdf).
- Black, Grant C., and Paula E. Stephan.** 2010. "The Economics of University Science and the Role of Foreign Graduate Students and Postdoctoral Scholars." In *American Universities in a Global Market*, edited by Charles T. Clotfelter, 129–61. Chicago: University of Chicago Press.
- Blanchard, Emily, John Bound, and Sarah Turner.** 2009. "Opening (and Closing) Doors: Country-Specific Shocks in U.S. Doctorate Education." Population Studies Center Report 09-674.
- Borjas, George J.** 2007. "Do Foreign Students Crowd Out Native Students from Graduate Programs?" In *Science and the University*, edited by Paula E. Stephan, and Ronald G. Ehrenberg. Madison: University of Wisconsin Press.
- Bothwell, Ellie.** 2018. "Insuring Against Drop in Chinese Students" *Inside Higher Ed*, November 29. <https://www.insidehighered.com/news/2018/11/29/university-illinois-insures-itself-against-possible-drop-chinese-enrollments>.
- Bound, John, Breno Braga, Joseph M. Golden, and Gaurav Khanna.** 2015. "Recruitment of Foreigners in the Market for Computer Scientists in the United States." *Journal of Labor Economics* 33 (S): S197–223.

- Bound, John, Breno Braga, Joseph M. Golden, and Sarah Turner.** 2013. "Pathways to Adjustment: The Case of Information Technology Workers." *American Economic Review* 103 (3): 203–07.
- Bound, John, Breno Braga, Gaurav Khanna, and Sarah Turner.** 2020. "A Passage to America: University Funding and International Students." *American Economic Journal: Economic Policy* 12 (1): 97–126.
- Bound, John, Murat Demirci, Gaurav Khanna, and Sarah Turner.** 2014. "Finishing Degrees and Finding Jobs: U.S. Higher Education and the Flow of Foreign IT Workers" *Innovation Policy and The Economy* 15 (2015).
- Bound, John, Sarah Turner, and Patrick Walsh.** 2009. "Internationalization of U.S. Doctorate Education." In *Science and Engineering Careers in the United States: An Analysis of Markets and Employment*, edited by R. B. Freeman and D. L. Goroff, 59–98. Chicago: University of Chicago Press.
- Bowen, William G., and Breneman, David W.** 1993. "Student Aid: Price Discount or Educational Investment?" *The Brookings Review* 11 (1).
- Bureau of Economic Analysis.** 2020. "International Transactions, International Services, and International Investment Position Tables." International Data. <https://apps.bea.gov/iTable/iTable.cfm?reqid=62&step=6&isuri=1&tablelist=245&product=4>. (accessed November 1, 2020).
- Canada Express Entry.** 2020. Canada Express Entry Eligibility. <https://www.canadaexpressentry.org/eligibility.php>. (accessed November 1, 2020).
- Chellaraj, Gnanaraj, Keith E. Maskus, and Aaditya Mattoo.** 2008. "The Contribution of International Graduate Students to US Innovation." *Review of International Economics* 16 (3): 444–62.
- Chen, Te-Ping, and Melissa Korn.** 2015. "American Colleges Pay Agents to Woo Foreigners, Despite Fraud Risk" *Wall Street Journal*, September 30. <https://www.wsj.com/articles/american-colleges-pay-agents-to-woo-foreigners-despite-fraud-risk-1443665884>.
- Condon, Christine.** 2020. "University System of Maryland chancellor takes pay cut, warns employees could 'share in the pain' of pandemic" *The Baltimore Sun*, September 9. <https://www.baltimoresun.com/education/bs-md-university-system-losses-chancellor-pay-cut-20200909-fmqwssllkncvjer22m37e3niiq-story.html>.
- Courant, Paul N., and Sarah Turner.** 2019. "Faculty Deployment in Research Universities." In *Productivity in Higher Education*, edited by Caroline M. Hoxby and Kevin Stange, 177–208. Chicago: University of Chicago Press.
- Crown, Daniel, Alessandra Faggian, and Jonathan Corcoran.** 2020. "Foreign-Born Graduates and Innovation: Evidence from an Australian Skilled Visa Program." *Research Policy* 49 (9).
- Demirci, Murat.** 2015. "OPT and The Impact of High Skill Immigration on Career Decisions of College-Educated Natives." Unpublished.
- Education Data Portal.** 2020. "Version 0.9.0, Urban Institute, Center on Education Data and Policy." <https://educationdata.urban.org/documentation/>. (accessed April 1, 2020).
- Finn, Michael, and Leigh Ann Pennington.** 2018. *Stay Rates of Foreign Doctorate Recipients from U.S. Universities, 2013*. Oak Ridge, TN: Oak Ridge Institute for Science and Education.
- Flaherty, Darryl.** 2020. "The Cost of COVID-19 for the University of Delaware" *Delaware Online*, October 3. <https://www.delawareonline.com/story/opinion/2020/10/03/cost-covid-19-university-delaware/5893911002/>.
- Gareis, Elisabeth.** 2012. "Intercultural Friendship: Effects of Home Region and Sojourn Location." *Journal of International and Intercultural Communication* 5: 309–28.
- Gaulé, Patrick, and Mario Piacentini.** 2013. "Chinese Graduate Students and US Scientific Productivity." *Review of Economics and Statistics* 95 (2): 698–701.
- Ghose, Devaki, and Sarah Turner.** 2020. "Enrollment as Access to Employment: Evidence from Foreign Student Enrollment in CS." Unpublished.
- Hechinger, Fred M.** 1979. "Iranians' Plight Puts a Spotlight on U.S. Colleges." *New York Times*, February 20. Section C, Page 4.
- Hunt, Jennifer, and Marjolaine Gauthier-Loiselle.** 2010. "How Much Does Immigration Boost Innovation?" *American Economic Journal: Macroeconomics* 2 (2): 31–56.
- Jordan, Miriam.** 2015. "International Students Stream into U.S. Colleges." *Wall Street Journal*, March 24. <http://www.wsj.com/articles/international-students-stream-into-u-s-colleges-1427248801>.
- Kahn, Shulamit, and Megan MacGarvie.** 2016. "Do Return Requirements Increase International Knowledge Diffusion? Evidence from the Fulbright Program." *Research Policy* 45 (6): 1304–22.
- Kato, Takao, and Chad Sparber.** 2013. "Quotas and Quality: The effect of H-1B Visa Restrictions on the Pool of Prospective Undergraduate Students from Abroad." *The Review of Economics and Statistics* 95 (1): 109–26.
- Kerr, William.** 2018. *The Gift of Global Talent: How Migration Shaped Business, Economy, & Society*. Stanford,

- CA: Stanford University Press.
- Khanna, Gaurav, and Nicolas Morales.** 2019. "The IT Boom and Other Unintended Consequences of Chasing the American Dream." <http://www-personal.umich.edu/~moralessn/Khanna%20Morales.pdf>.
- Khanna, Gaurav, Kevin Shih, Ariel Weinberg, Mingzhi Xu, and Miaojie Yu.** 2020. "Trade Liberalization and Chinese Students in US Higher Education." Unpublished.
- Larmer, Brook.** 2019. "One of America's Most Vital Exports, Education, Never Goes Abroad, but It Still Faces Threats." *The New York Times*, January 3. <https://www.nytimes.com/2019/01/03/magazine/one-of-americas-most-vital-exports-education-never-goes-abroad-but-it-still-faces-threats.html>.
- Moltaji, Golbon.** 2017. "Exploring the Sensory Terrain of Mobility among Graduates Who Immigrate to Canada via Post Graduate Work Permit Program" PhD diss. proposal. University of Ottawa.
- Murphy, Kate.** 2020. "More Employees See Cuts as NC Universities Face Sharp Financial Losses Due to COVID-19." *The News & Observer*, September 24. <https://www.newsobserver.com/news/local/education/article245916490.html>.
- Najar, Nida.** 2011. "Squeezed Out in India, Students Turn to U.S." *New York Times*, October 13. <https://www.nytimes.com/2011/10/14/world/asia/squeezed-out-in-india-students-turn-to-united-states.html>.
- National Association for College Admission Counseling.** 2018. "Trends in Commission-Based International Student Recruitment." [https://www.nacacnet.org/globalassets/documents/knowledge-center/international/agent-series\\_part-1-cr.pdf](https://www.nacacnet.org/globalassets/documents/knowledge-center/international/agent-series_part-1-cr.pdf).
- National Center for Education Statistics.** 2018. Integrated Postsecondary Education Data System Enrollment. "Integrated Postsecondary Education Data System Enrollment." <https://nces.ed.gov/ipeds/>. (accessed April 1, 2020).
- National Science Board.** 2020. National Science Foundation, Science & Engineering Indicators. <https://nces.nsf.gov/pubs/nsb20202/>. (accessed April 1, 2020).
- Radnofsky, Louise.** 2019. "U.S. Changes Visa Process for High-Skilled Workers." *Wall Street Journal*, January 31. <https://www.wsj.com/articles/u-s-changes-visa-process-for-high-skilled-workers-11548879868>.
- Redden, Elizabeth.** 2014. "Integrating International Students, So You Have X Number of International Students on Your Campus. So What?" *Inside Higher Ed*, February 20. <https://www.insidehighered.com/news/2014/02/20/gathering-senior-international-educators-integration-international-students-was>.
- Redden, Elizabeth.** 2017. "Boom in Indian Enrollments, Followed by Bust." *Inside Higher Ed*, October 30. <https://www.insidehighered.com/admissions/article/2017/10/30/after-huge-surge-enrollment-india-central-missouri-sees-substantial>.
- Rosenzweig, Mark.** 2006. "Global Wage Differences and International Student Flows." *Brookings Trade Forum* 57–86.
- Saudi Arabian Cultural Bureau.** 2014. "KASP Scholarship Program." <https://www.saudibureau.org/en/inside.php?ID=16>. (accessed April 1, 2020).
- Saxenian, AnnaLee.** 2000. *Silicon Valley's New Immigrant Entrepreneurs*. Santa Clara, CA: Public Policy Institute of California.
- Shanghai Ranking, Consultancy.** 2020. "Academic Ranking of World Universities 2018." <http://www.shanghairanking.com/ARWU2018.html>. (accessed April 1, 2020).
- Shih, Kevin.** 2017. "Do International Students Crowd-out or Cross-subsidize Americans in Higher Education?" *Journal of Public Economics* 156: 170–84.
- Stuen, Eric T., Ahmed Mushfiq Mobarak, and Keith E. Maskus.** 2012. "Skilled Immigration and Innovation: Evidence from Enrolment Fluctuations in US doctoral Programmes." *The Economic Journal* 122(565): 1143–76.
- UNESCO Institute for Statistics.** 2018. "Education Data." UIS database. <http://data.uis.unesco.org/>. (accessed April 1, 2020).
- United States Department of State.** 2020. *Monthly Non-Immigrant Visa Issuances*. Washington, DC: United States Department of State.
- United States Citizenship and Immigration Services.** 2015. "F-1 visa recipients (2004–2015)." obtained through a Freedom of Information request.
- Wadhwa, Vivek, AnnaLee Saxenian, Ben Rissing, and Gary Gereff.** 2007. "America's New Immigrant Entrepreneurs." <https://www.immigrationresearch.org/report/duke-university/americas-new-immigrant-entrepreneurs-part-i>.
- World Bank.** 2020. "GDP per capita, PPP (current international \$)." *World Development Indicators database*. *The World Bank Group*. <https://data.worldbank.org/indicator/NY.GDP.PCAP.PP.CD> (accessed April 1, 2020).